

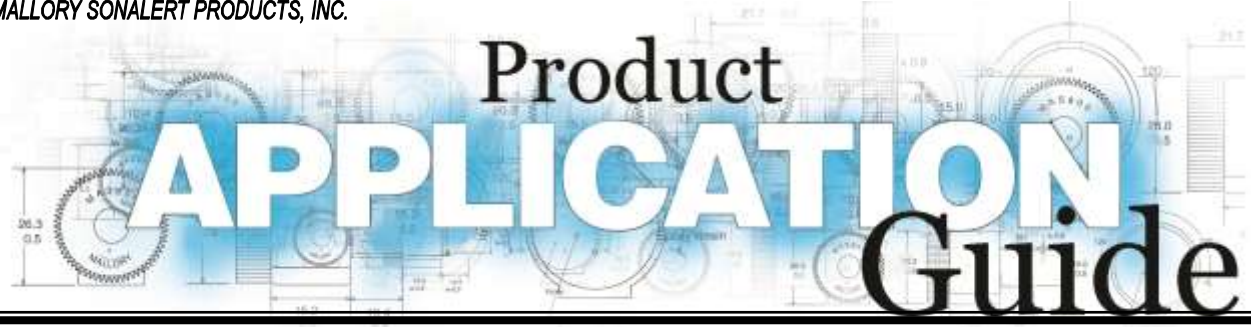

MALLORY SONALERT PRODUCTS, INC.



Stack Light- Light Only

Part Number Structure

JT 028 - RYGBC - C D

Series: **JT** = Triangle Shaped Stack Light

Maximum Voltage:

028 = 20 – 28 Vac/dc; **120** = 90 – 120 Vac Only

Stack Colors:

R = Red; **Y** = Yellow/Amber; **G** = Green; **B** = Blue; **C** = Clear/White

Light Function: **C** = Continuous On

Mounting Type: **D** = Direct; **S** = Stainless Pole

Stack Light with Sound

Part Number Structure

JT 028 - RYGBC - C D L

Series: **JT** = Triangle Shaped Stack Light

Maximum Voltage:

028 = 20 – 28 Vac/dc; **120** = 90 – 120 Vac Only

Stack Colors:

R = Red; **Y** = Yellow/Amber; **G** = Green; **B** = Blue; **C** = Clear/White

Light Function: **C** = Continuous On

Mounting Type: **D** = Direct; **S** = Stainless Pole

Sound Loudness (Typical @ 1 Meter):

L = Loud (80 to 85 dB); **M** = Medium (70 to 75 dB)

Stack Light Instructions

Warnings:

- Turn power off before installation, repair, or maintenance to avoid shock (potentially fatal), burns, or damage to the stack light and the equipment in which it is installed.
- This unit is not designed to support any external weight. It is not to be used as a hand-hold or support for a person.

Cautions:

- This unit is rated for indoor use only.
- It is not recommended to install this unit sideways or inverted.
- Make sure that the unit is rated for the voltage being applied.
- It is recommended to only use a slightly damp cloth to clean this unit. Other cleaning agents could affect the waterproof integrity or mar the surface finish potentially affecting its visual characteristics.
- Do not push or pull on wires.

Pole Mounting:

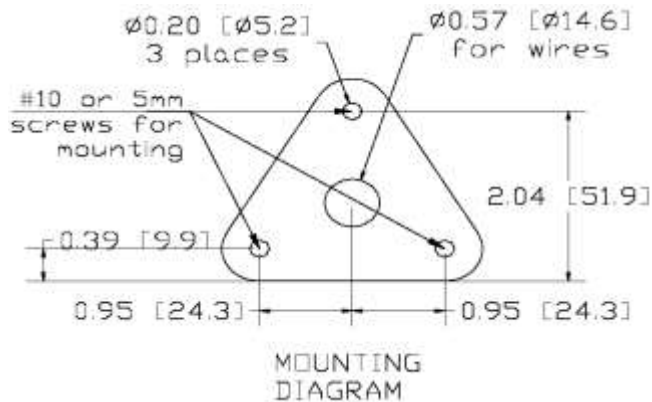

1. The diagram on the left details the 4 holes needed for the pole-mount bracket. The center hole size of 0.57" (14.6 mm) is the minimum size and can be larger.
2. Use three standard #10 or 5mm screws (not included), or alternately, use self-taping screws.
3. Before drilling holes, use a nail punch to mark the center of the screw hole locations.
4. When inserting wires through the center hole, be careful not to pinch the wires under the bracket.
5. Be careful not to over-torque the screws which can cause the plastic bracket to crack.
6. The gasket on the bottom of the bracket is needed to ensure waterproof ratings. Do not remove.
7. If the installation surface is not flat, silicone adhesive may be needed to ensure waterproof ratings.

Direct Mounting:

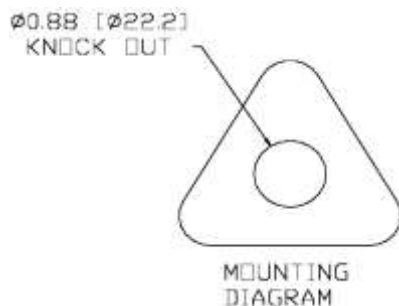

1. Per the diagram on the left, drill or punch a 0.88" (22.2 mm) hole into the installation surface.
2. Remove the nut from the stack light pipe.
3. Carefully insert the wires and stack light pipe through the hole being careful not to pinch the wires.
4. Put the nut over the wires and carefully thread the nut onto the stack light pipe.
5. Tighten the nut making sure not to over-torque the nut.
6. To ensure waterproof ratings, it is recommended to use Teflon tape on the pipe threads

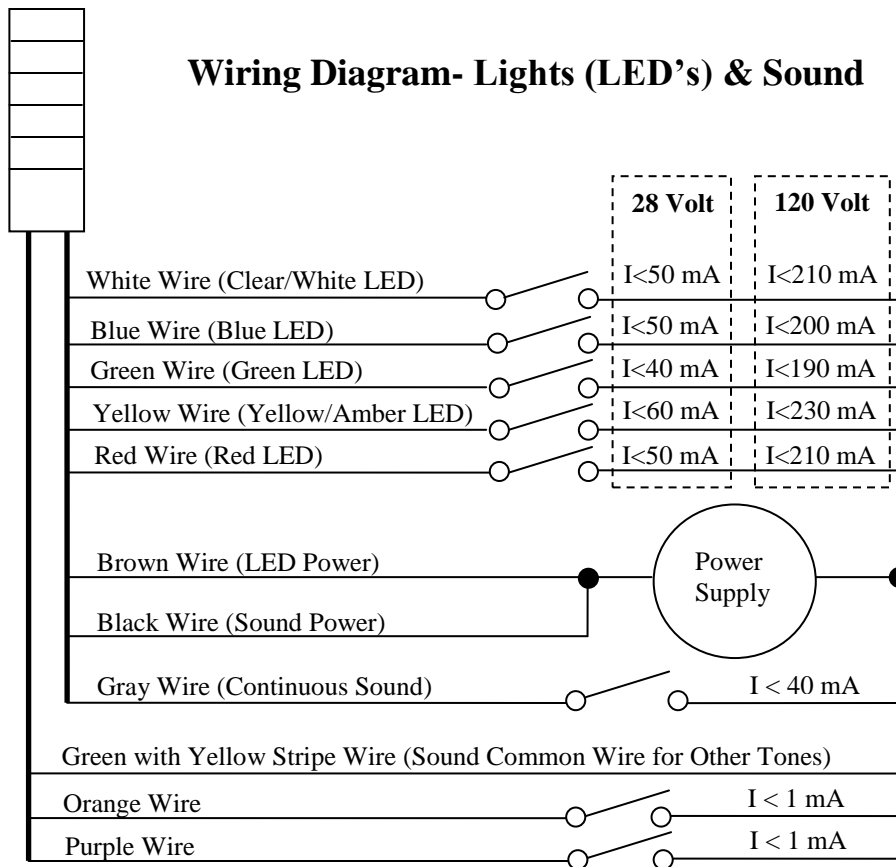

Notes:

1. Transistors or FET's can be used as switches as long as the device can handle the current draws listed.
2. Stack lights will only be supplied with the number of wires needed to operate that particular model of stack light. The above diagram is for 5 stacks and sound. If your stack light model has less than 5 stacks and/or does not come with sound, not all of the above wires will be present.
3. The stack light models are all non-polar. If connecting to a 24 Vdc power supply, it does not matter which way power supply's plus and negative terminals are connected in the above diagram.
4. The sound and LED lights operate independently of each other.
5. Do not connect the green with yellow stripe wire to power. This will likely cause the unit to fail and void the warranty.
6. In order for any sound tone to be generated, the gray and black wires must be connected to the power supply. When only the gray and black sound wires are connected, a continuous tone will be heard. To activate the other tones, the orange and purple wires must be connected to the green with yellow stripe wire in various configurations. See the Sound Control Diagrams on how to activate the four different sounds.

LED Operation: The brown wire must be connected to one side of the power supply and the appropriate LED stack color wire connected to the other side of the power supply. One or more stacks can be activated at the same time.

Sound Control Diagrams

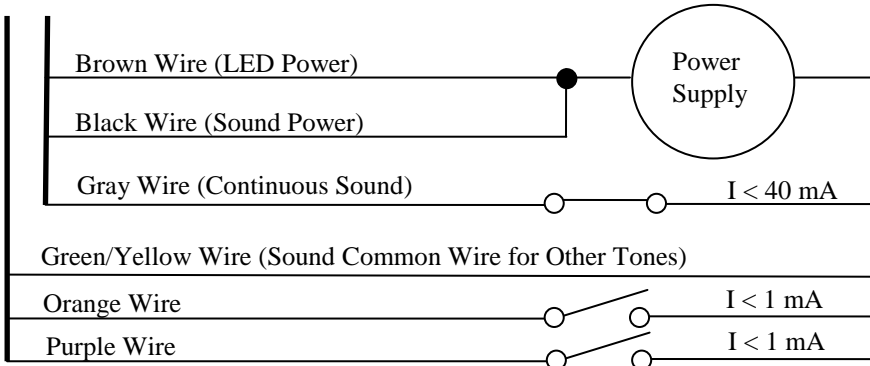

Continuous Sound

Connect the black wire to one side of the power supply and connect the gray wire to the other side.

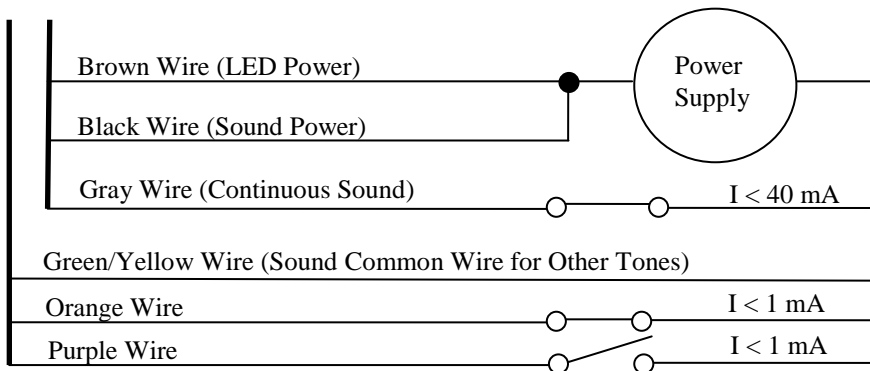

Medium Pulse Sound

Connect the black wire to one side of the power supply and connect the gray wire to the other side.

At the same time, connect the green with yellow stripe wire to the orange wire.

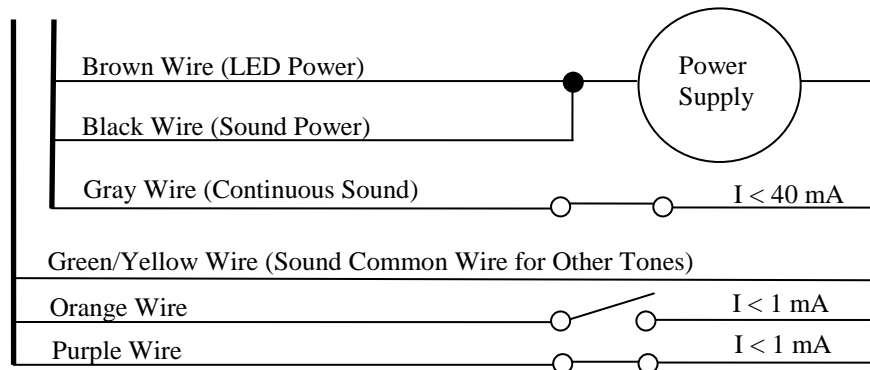

Double Pulse Sound

Connect the black wire to one side of the power supply and connect the gray wire to the other side.

At the same time, connect the green with yellow stripe wire to the purple wire.

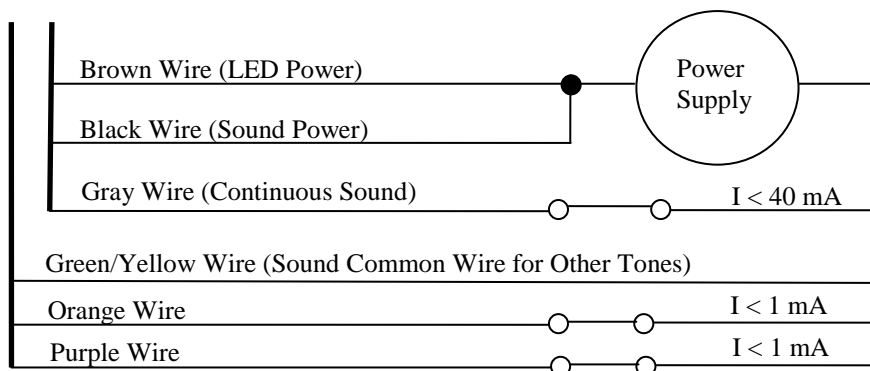

Continuous/Short Pulse Sound

Connect the black wire to one side of the power supply and connect the gray wire to the other side.

At the same time, connect the green with yellow stripe wire both to the orange wire and the purple wire.

Piezoelectric Electronic Alarm Construction

Piezoelectric Audible Signal Basic Construction

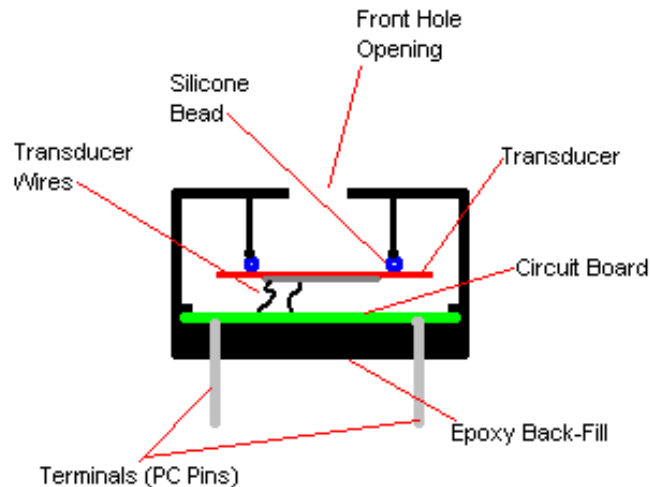

The above cross section picture shows the basic elements used in a piezoelectric audible alarm. The area in front of the transducer element including the front hole opening forms an acoustic cavity that lets the sound radiate out with the most efficiency (i.e. loudest sound level). If the alarm is an indicator that contains a circuit board, the circuit board is attached to the piezoelectric sounder element via soldered wires.

The above picture can be interpreted to represent a board mount package with pc pin terminations, but the same concept is used when building audible alarms in other mounting configurations such as SMT, Flange Mount, and Panel Mount alarms.

If the back of the alarm is sealed with epoxy or other material, the “guts” of the alarm (including the circuit board and components) are protected against fluid intrusion. However, fluid sitting inside the front cavity can obstruct the operation of the device causing the sound level to decrease significantly. If you need to wash the alarms after a soldering operation, it is strongly recommended to use an alarm that comes with a wash label that keeps the washing fluid from getting inside of the front cavity.

Operation of Piezoelectric Audible Alarms

Piezoelectric electronic audible alarms work by converting the user input voltage to an appropriate oscillating signal that is applied to a sounder element that is mounted in a housing. The piezoelectric sounder element consists of a metal disc that has a special ceramic material bonded to it that physically bends when voltage is applied to it.

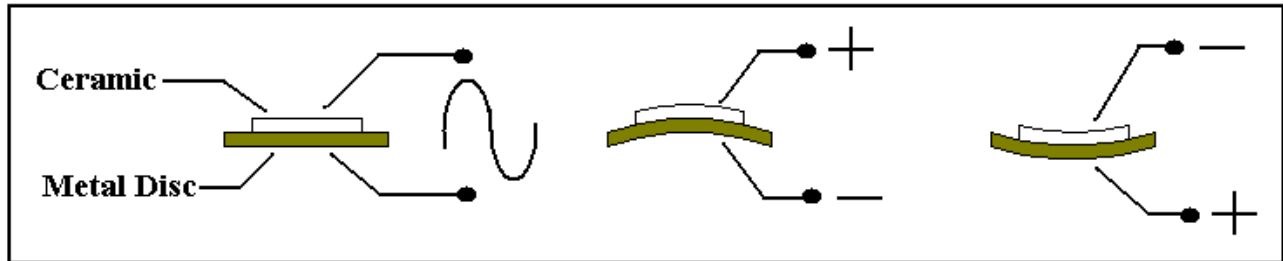

The above picture shows a bare piezoelectric sounder element. By applying a sinusoidal wave-form at an appropriate frequency, the transducer will physically deflect in one direction and then in the opposite direction following the shape of the input wave-form. If this oscillation occurs in the audible frequency range (1 Hz to 20 kHz), then air pressure waves are produced that the human ear interprets as an audible sound.

The larger the voltage of the applied wave-form, the larger the amplitude of the air pressure waves resulting in a louder sound level. However, the ceramic portion of the transducer can only bend so far before there is a risk of a catastrophic failure. This maximum voltage is somewhere around 40 to 50 volts. However, it is rare to apply this much voltage to a transducer as you reach a point of diminishing returns for voltages much greater than 32 volts.

By itself, the sound level produced by a transducer element is insignificant. To increase the size of the air pressure waves (and thus the sound level), the transducer element must be mounted inside an acoustic chamber that is optimized for the transducer size and resonant frequency. Every transducer has one frequency where it flexes more efficiently producing the louder sound levels. This frequency where the transducer performs the best is called the resonant frequency.

Self-Drive type devices provide a 3rd terminal that connects to an isolated portion of the piezoelectric transducer. This third terminal provides a feed-back signal that is 180 degrees out of phase with the drive signal. This signal can be fed back into the circuit to allow the sounder element to self-tune itself to the transducer's resonant frequency.

Decibel Sound Level Scale

The decibel sound level scale is an arbitrary scale that ranges from 0 dB (threshold of hearing) to 130 dB (threshold of pain). The chart below shows where some common sounds fall on this dB scale. Audible alarms are available that have sound levels as soft as 55 dB at 2 feet and as loud as 110 dB at 2 feet.

Reference Sound Levels

(as if you were standing 2 feet from the sound source)

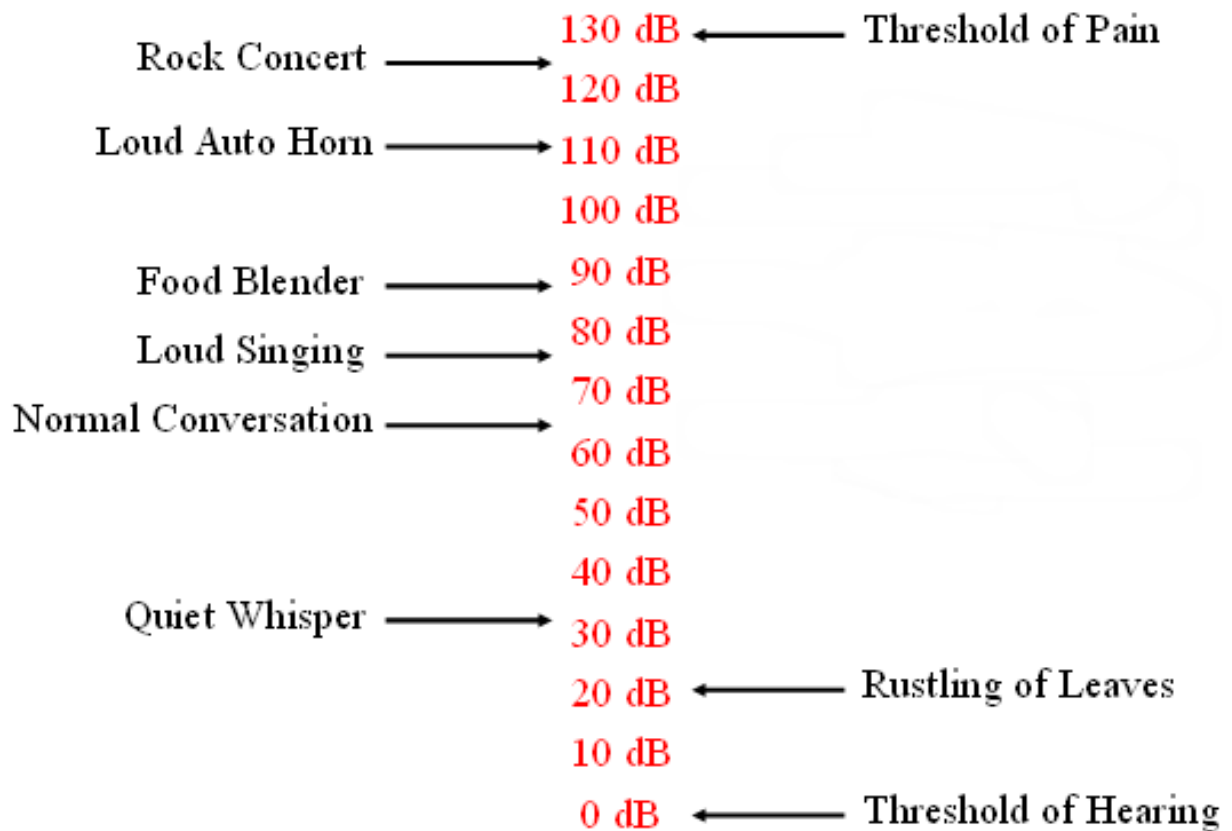

Fundamental Frequency & Harmonics

Below is a frequency scan of a piezoelectric audible alarm that has a resonant frequency of 2,800 Hz. As you can see, there is a strong frequency peak at 2.8 kHz and several smaller frequency peaks that follow called harmonic frequencies. The table below the chart shows that the size of the harmonic frequencies are significantly smaller than the fundamental frequency for this particular alarm unit. Because this alarm has a large fundamental frequency and much smaller harmonic frequencies, the sound quality of this part will be very good. When this alarm is activated, the listener will hear one clear frequency (also called sound pitch) from the alarm. Other electronic alarm technologies such as electro-magnetic or electro-mechanical type alarms often have much larger harmonic frequency components resulting in less clear tone.

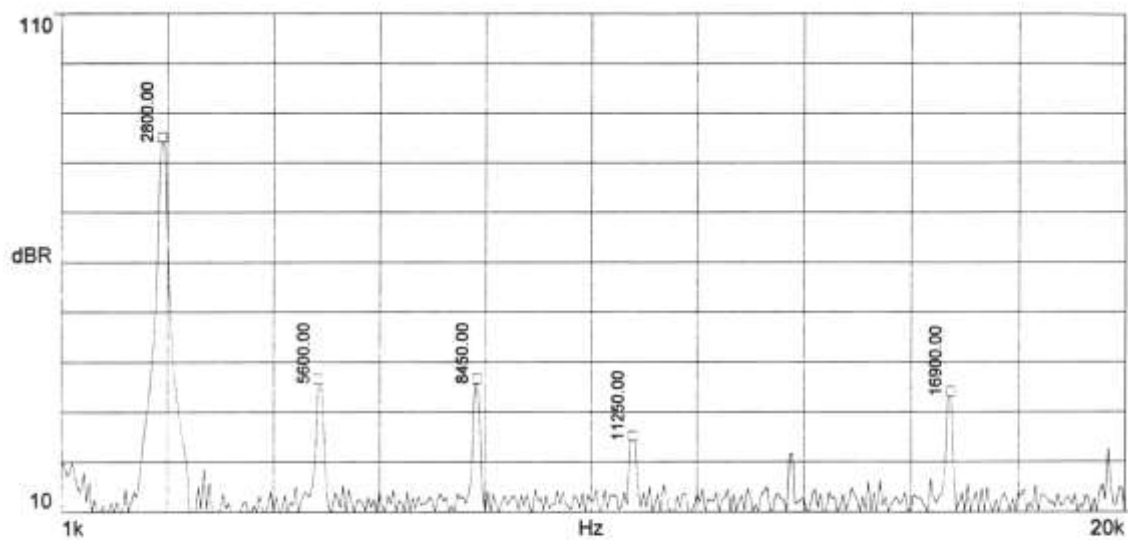

	Frequency	dB	% dB of Fundamental
Fundamental:	2.800 KHz	86.1	100.0%
2nd Harmonic:	5.600 KHz	37.6	43.7%
3rd Harmonic:	8.450 KHz	37.6	43.7%
4th Harmonic:	11.250 KHz	26.1	30.3%